

# THE SOLID DIFFERENCE

## DIFFERENCE

The Ray Oil Tool Company's Solid Casing Centralizers DO make a difference. The 90% casing/wellbore stand-off that they support has been the needed characteristic for getting a good primary cement job EVERY TIME.

With cement coverage completely around the casing YOU GET:

- Better Perforation Performance
- No Premature Saltwater
- No Sand (sand is produced only with saltwater in most wells)
- No Remedial Workovers
- No Lost Reserves
- The BEST Investment Ever!

## PROFITS

Since Ray Oil Tool Company introduced Solid Casing Centralizers in 1984, they have become the most profitable well equipment run in the wellbore today. Profits which are realized from achieving a good primary cement job every time.



Centralized  
"Tornado"  
Up-Jet Action

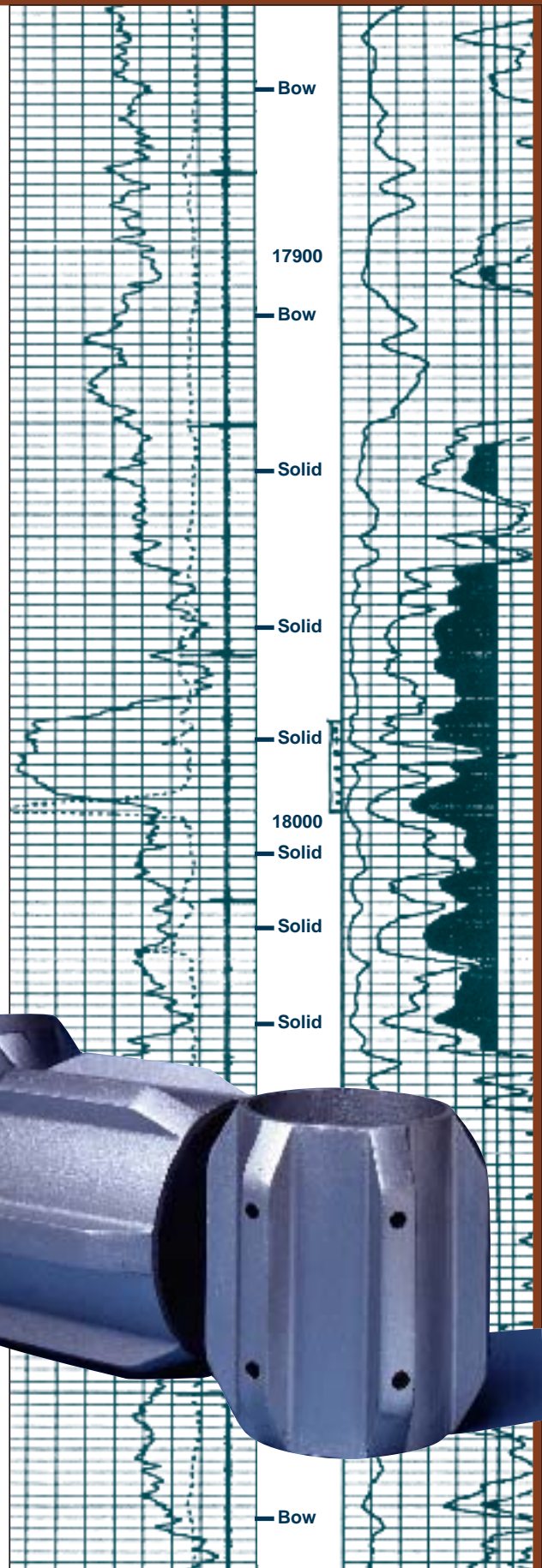
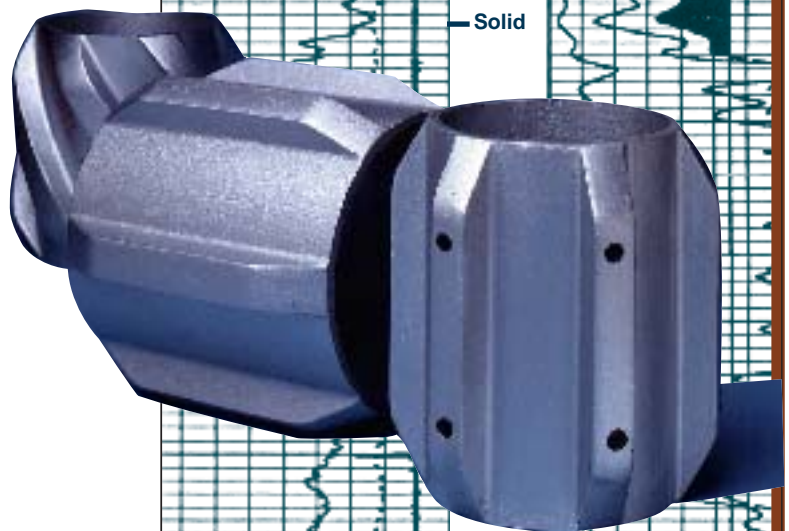

COPYRIGHT © MURPHY PUBLISHING, INC. 1996

Leading Independent Completion  
in Morrow Sands, Roger Mills County, Oklahoma